

SALES & ENGINEERING DATA

RATIO SERIES: **1:1**

FLUID P.S.I. RANGE: **20 - 120**

66610X-XXX-C

1" METALLIC DIAPHRAGM PUMP

RELEASED: 12-20-96
 REVISED: 6-7-10
 (REV. 04) S-878

DIMENSIONAL DATA

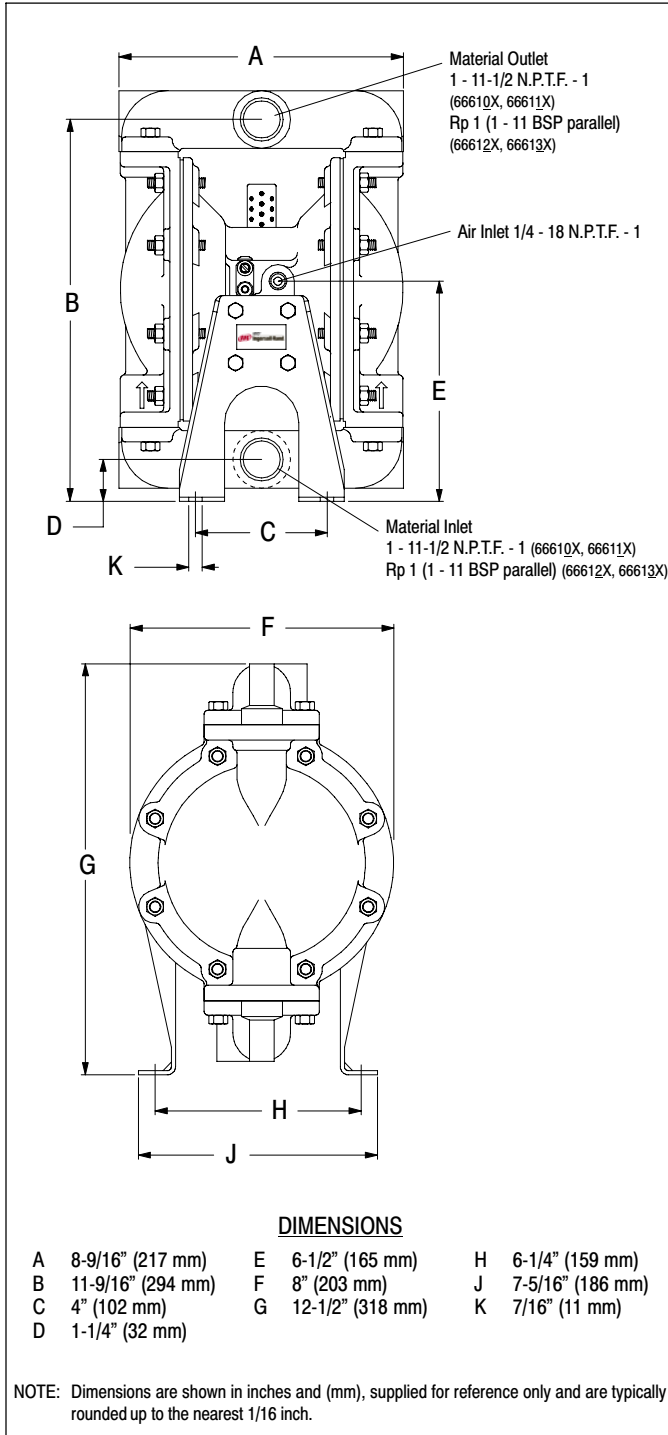

SPECIFICATIONS

CONSTRUCTION

Model Series	66610X-XXX-C
Pump Type	Metallic, Air Operated, Double Diaphragm
Ratio	1:1
Material Inlet / Outlet (female)	
66610X-X-C and 66611X-X-C ...	1 - 11-1/2 N.P.T.F. - 1
66612X-X-C and 66613X-X-C ...	Rp 1 (1 - 11 BSP parallel)
Air Inlet (female)	1/4 - 18 N.P.T.F. - 1
Air Exhaust (female)	3/8 - 18 N.P.T.F. - 1
Weight Aluminum	19 lbs (8.62 kgs)
Cast Iron	31 lbs (14.06 kg)
Stainless Steel	36 lbs (16.33 kgs)
	(add 8 lbs (3.63 kgs) for cast iron air motor section)
Air Section Service Kit	637118-C
Fluid Section Service Kit	637119-XX-C

66610X - X -C
 637119 - -C

Diaphragm Material
 Ball Material

EXAMPLE: Model 666100-361-C
 Fluid Section Service Kit is 637119-61-C

PERFORMANCE

Air Inlet Pressure Range	20 - 120 p.s.i. (1 - 8.3 bar)
Maximum Material Inlet Pressure ...	10 p.s.i. (0.69 bar)
Fluid Pressure Range	20 - 120 p.s.i. (1 - 8.3 bar)
Maximum Flow Rate (flooded inlet)	35 g.p.m. (133 l.p.m.)
Maximum Particle Size	1/8" dia. (3.2 mm)
Maximum Temperature Limits (diaphragm / ball / seal material)	
Acetal	10° to 180° F (-12° to 82° C)
E.P.R. / EPDM	-60° to 280° F (-51° to 138° C)
Hytrek	-20° to 150° F (-29° to 66° C)
Neoprene	0° to 200° F (-18° to 93° C)
Nitrile	10° to 180° F (-12° to 82° C)
Polypropylene	35° to 150° F (2° to 66° C)
Polyurethane	10° to 150° F (-12° to 66° C)
P.V.D.F. (Kynar)	10° to 200° F (-12° to 93° C)
Santoprene	-40° to 225° F (-40° to 107° C)
PTFE	40° to 225° F (4° to 107° C)
Viton	-40° to 350° F (-40° to 177° C)

Displacement / Cycle @ 100 p.s.i. ... 0.16 gal. (0.60 lit.)

Noise Level @ 70 p.s.i. - 60 c.p.m. ① 64.5 db(A)②

① Tested with 93110 muffler installed.
 ② The pump sound pressure level has been updated to an Equivalent Continuous Sound Level (L_{Aeq}) to meet the intent of ANSI S1. 13-1971, CAGI-PNEUROPS S5.1 using four microphone locations.

ACCESSORIES:

- 65010 Neoprene "O" Ring Air Motor Kit
- 65764 Viton "O" Ring Air Motor Kit
- 66073-2 Air Line Connection Kit
- 637167 Abrasion Resistant Conversion Kit

PERFORMANCE CURVES

6661XX-XXX-C 1" METALLIC DIAPHRAGM PUMP

