

### FEATURES

- Ruggedly built valve, particularly recommended for use with steam, superheated water, corrosive fluids
- High-performance, maintenance-free stuffing box, resistant to thermal shock
- Mixer function (two pressure inlets at 1 or 3, one outlet at 2) or distributor function (one pressure inlet at 2, two outlets at 1 and 3)
- Vacuum operation up to 10<sup>-2</sup> mbar
- Allowable backpressure: up to 40 bar
- Optical position indicator as standard
- Autoclavable valve for use at high ambient temperatures (up to 180°C)
- The valves satisfy Pressure Equipment Directive 97/23/EC, category 1 (DN > 32) or article 3.3 (DN ≤ 32)

### GENERAL

Differential pressure	0 to 40 bar [1 bar = 100 kPa]
Maximum allowable pressure	40 bar (within the specified limits, see diagram I)
Ambient temperature range	-25°C to +180°C
Maximum viscosity	5000 cSt (mm <sup>2</sup> /s)
Pilot fluid	Air
Max. pilot pressure	10 bar
Min. pilot pressure	See below



fluids (*)	temperature range	disc seal (*)
DN 15-20-25 : air and gas groups 1 & 2 DN 32-40-50 : air and gas group 2 all DN : superheated water, liquids groups 1 & 2 and steam	- 10°C to + 250°C	bronze PTFE

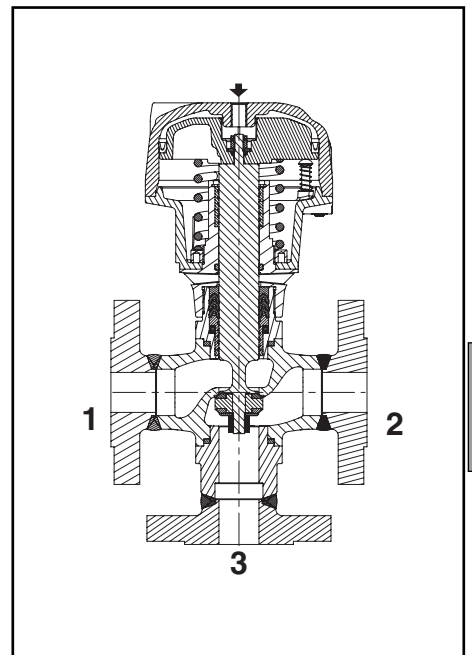
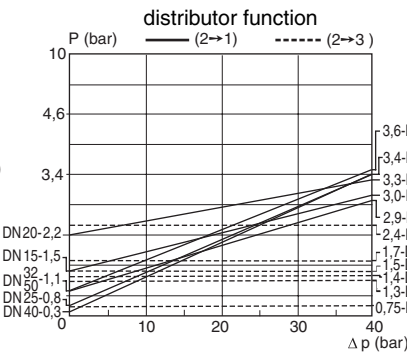
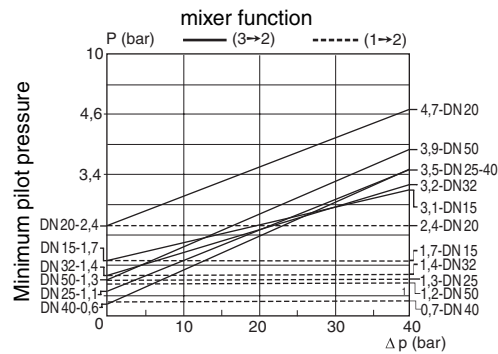

### CONSTRUCTION

Connection	Flanges PN40, type 21 (ISO 7005 / EN 1092)
Face-to-face dimensions	ANSI Class 300 ANSI B16-5
Facing	EN 558-1
	Type B

### MATERIALS IN CONTACT WITH FLUID

(*) Ensure that the compatibility of the fluids in contact with the materials is verified	
Body and plug	Stainless steel
Stuffing box housing	Stainless steel
Stem, disc	Stainless steel
Stuffing box packing	PTFE chevrons
Disc seal	Bronze PTFE
Valve body seal	Graphite

### OTHER MATERIALS

Operator	Aluminium, nickel plated
----------	--------------------------

### SPECIFICATIONS

DN	orifice size	flow coefficient Kv								pilot pressure (bar)		operating pressure differential (bar)	operator diameter (mm)	catalogue number		
		mixer				distributor				min.	max.			DIN	ANSI 300	
		3→2	1→2	2→3	2→1	(m <sup>3</sup> /h)	(l/min)	(m <sup>3</sup> /h)	(l/min)							
<b>U - Universal</b>																
15	15	3,3	54	4,4	73	3,5	59	4,6	78	*	10	40	80	T398A001	T398A007	
20	20	8,0	133	7,4	123	8,1	136	7,7	129	*	10	40	100	T398A002	T398A008	
25	25	11,4	190	11,6	194	12,1	203	11,9	199	*	10	40	100	T398A003	T398A009	
32	32	18,9	316	16,6	278	17,9	299	16,6	278	*	10	40	150	T398A004	T398A010	
40	40	27	450	27	450	27	450	27	450	*	10	40	150	T398A005	T398A011	
50	50	51	850	51	850	51	850	51	850	*	10	40	200	T398A006	T398A012	

\* Minimum pilot pressure varies with differential pressure. See piloting charts above.

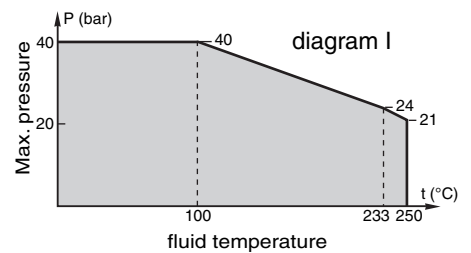

### OPTIONS AND ACCESSORIES

- Metal-to-metal sealing disc
- ATEX 94/9/EC versions for potentially explosive atmospheres, categories 2 GD and 3 GD
- Valve seat leakage class VI as defined by FCI 70-2, contact us
- Other pipe connections are available on request

### INSTALLATION

- The valves can be mounted in any position without affecting operation
- Compatible with ASTM 1, 2 and 3 oils
- Installation/maintenance instructions are included with each valve

### SPARE PARTS KITS

catalogue number	spare parts kit no.		
	piston seal	actuator spring	stem, disc, seals
T398A001/007	C140233	C140299	C140323
T398A002/008	C140234	C140301	C140324
T398A003/009	C140234	C140303	C140225
T398A004/010	C140235	C140305	C140326
T398A005/011	C140235	C140307	C140327
T398A006/012	C140298	C140309	C140328

### ORDERING EXAMPLES:

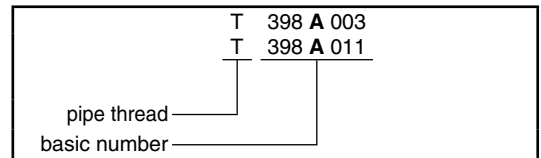

### ORDERING EXAMPLES / KITS:

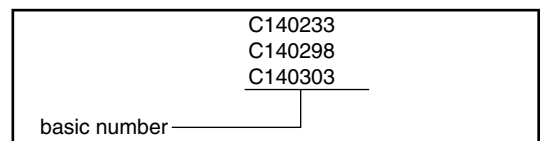

### DIMENSIONS (mm), WEIGHT (kg)



**TYPE 01-02-03-04**  
Prefix "T"

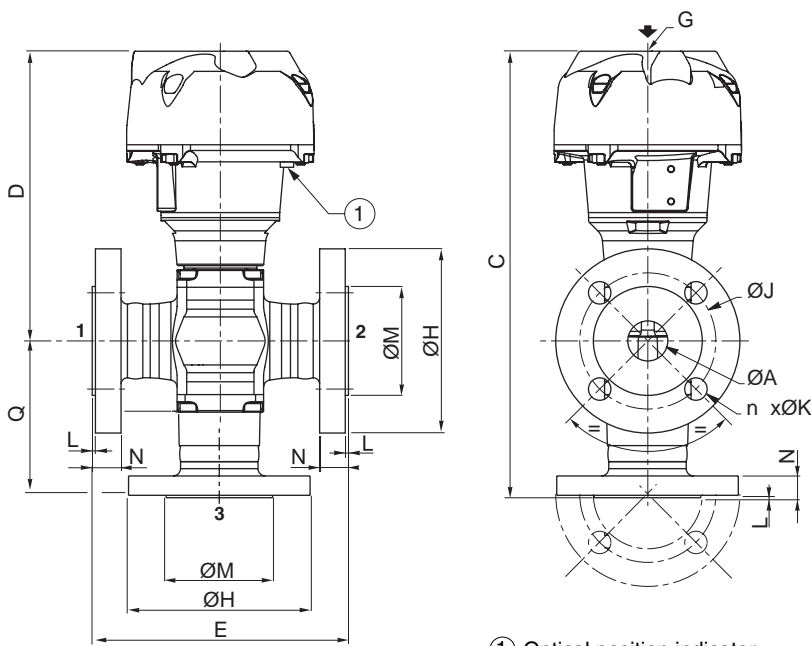

DN 50 - ANSI

TOP VIEW

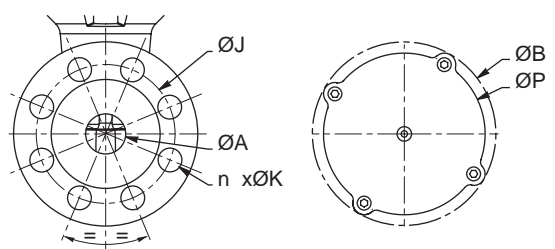

① Optical position indicator

type	DN	operator diameter	weight	
			DIN	ANSI
01	15	80	4,1	3,9
	20	100	6,7	7,2
02	25	100	8,1	8,7
	32	150	15,1	15,2
03	40	150	20,1	20,9
	50	200	33,9	34,3

type	DN	operator diameter	ØA	ØB	C		D	E		G	ØH		ØJ		n x ØK		L		ØM		N		ØP		Q	
					DIN	ANSI		DIN	ANSI		DIN	ANSI	DIN	ANSI	DIN	ANSI	DIN	ANSI	DIN	ANSI	DIN	ANSI	DIN	ANSI	DIN	ANSI
01	15	80	15	110	225,6	231,5	151,6	130	140	G 1/8	95	65	66,5	4 x 14	4 x 16	2	1,6	45	35	16	14,2	95	75	80		
					256,9	170,9		150	G 1/8		105	120	75	82,5	4 x 14	4 x 19	2	1,6	58	43	18	15,8	117	86		
02	25	100	25	132,5	275,9	280,9	180,9	160	170	G 1/8	115	125	85	89	4 x 14	4 x 19	2	1,6	68	51	18	17,5	117	95	100	
					346,2	351,2		180	190		G 1/4	140	135	100	98,5	4 x 18	4 x 19	2	1,6	78	64	18	19,1	172,5	109	114
03	40	150	40	191	396,2	259,2	200	200		G 1/4	150	155	110	114,5	4 x 18	4 x 22	2	1,6	88	73	18	20,6	172,5	137		
					474	328,5		230	G 1/4		165	125	127	4 x 18	8 x 19	2	1,6	102	92	20	22,4	230	145,5			