

FEATURES

- Compact and low weight valve enabling easy installation
- Two maximum pressure ratings depending on coil power
- AC/DC interchangeability of the solenoid head without any need for disassembly of the valve
- The solenoid valves satisfy all relevant EC directives

GENERAL

Differential pressure See «SPECIFICATIONS» [1 bar = 100 kPa]
Maximum viscosity 40 cSt (mm²/s)
Response time 8 - 20 ms

fluids (*)	temperature range (TS)	seal materials (*)
air, inert gas, water, oil	- 25°C to + 80°C	NBR (nitrile)

MATERIALS IN CONTACT WITH FLUID

(*) Ensure that the compatibility of the fluids in contact with the materials is verified

	Brass body	Stainless steel body
Body	Brass	AISI 316L (1.4404)
Internal parts	Stainless steel	Stainless steel
Springs	Stainless steel	Stainless steel
Seat	Brass and stainless steel	Stainless steel
Seals	NBR	NBR
Shading coil	Copper	Copper

ELECTRICAL CHARACTERISTICS

Coil insulation class F
Connector Spade plug (cable Ø 6-10 mm)
Connector specification ISO 4400 / EN 175301-803, form A
Electrical safety IEC 335
Electrical enclosure protection Moulded IP65 (EN 60529)
Standard voltages DC (=): 24V - 48V
 (Other voltages and 60 Hz on request) AC (~): 24V - 48V - 115V - 230V / 50 Hz

prefix option	power ratings				operator ambient temperature range (TS) (C°)	replacement coil		type ⁽¹⁾
	inrush ~	holding ~		hot/cold =		~	=	
	(VA)	(VA)	(W)	(W)		230 V/50 Hz	24 V DC	
SC	23	14	8	8 / 10,8	-25 to + 60	43005096	43005099	01
	55	23	10,5	9 / 11,2	-25 to + 60	400425-117	400425-142	02

⁽¹⁾ Refer to the dimensional drawings on the following page.

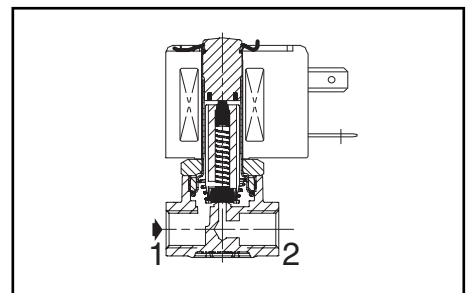

NC function

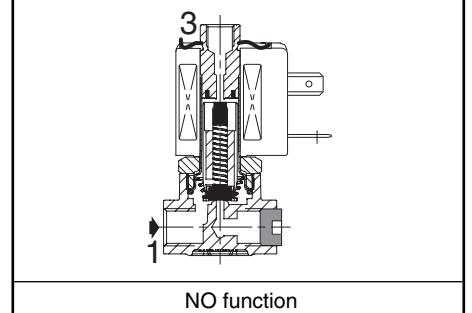

NO function

SPECIFICATIONS

pipe size	orifice size	flow coefficient Kv		operating pressure differential (bar)				power coil (W)		catalogue number				options			
				max. (PS)						brass		stainless steel		maintained man. operator	FPM	EPDM	
				min.	air (*)		water/oil (*)			~	=	~	=				
(G*)	(mm)	(m ³ /h)	(l/min)		~	=	~	=	~	=	~	=					
NC - Normally closed																	
1/4	2	0,11	1,8	0	40	15	40	15	8	10,8	SCE272A001		SCE272A031		MS	V	E
					40	40	40	40	10,5	11,2	SCE272A016		SCE272A046		MS	V	E
	2,7	0,22	3,6	0	30	4	30	4	8	10,8	SCE272A002		SCE272A032		MS	V	E
					40	15	40	15	10,5	11,2	SCE272A017		SCE272A047		MS	V	E
	3,8	0,32	5,3	0	15	2	15	2	8	10,8	SCE272A003		SCE272A033		MS	V	E
					20	8	20	8	10,5	11,2	SCE272A018		SCE272A048		MS	V	E
	4,5	0,42	7	0	10	1,5	10	1,5	8	10,8	SCE272A004		SCE272A034		MS	V	E
					16	5	16	5	10,5	11,2	SCE272A019		SCE272A049		MS	V	E
	5,5	0,63	10,5	0	6	1	6	1	8	10,8	SCE272A005		SCE272A035		MS	V	E
					10	2	10	2	10,5	11,2	SCE272A020		SCE272A050		MS	V	E
NO - Normally open																	
1/4 ⁽²⁾	2,5	0,2	3,3	0	20	-	10	-	8	-	SCE272A007		SCE272A037		MS	V	E
					20	20	10	10	10,5	11,2	SCE272A022		SCE272A052		MS	V	E

⁽²⁾ Size of port 1: 1/4, size of Port 3: G 1/8.

OPTIONS

- Valves can also be supplied with FPM (fluoroelastomer) and EPDM (ethylene-propylene) seals and discs. Use the appropriate optional suffix letter for identification
- Waterproof enclosure with embedded screw terminal coil according to protection class IP67, CEE-10 (prefix WP or WS)
- Explosionproof enclosures for use in zones 1/21-2/22, categories 2-3 to ATEX Directive 94/9/EC (see "Explosionproof solenoids" section)
- Compliance with "UL", "CSA" and other local approvals available on request
- Oxygen service with seals and disc in FPM, suffix N, example: SCE272A016 NV
- Other pipe connections are available on request
- Solenoid operated drain valve assembly with electronic timer (see Solenoids, Coils & Accessories section)
- Plug with visual indication and peak voltage suppression or with cable length of 2 m (see Solenoids, Coils & Accessories section)

INSTALLATION

- The solenoid valves can be mounted in any position without affecting operation
- Brass solenoid valves have 2 mounting holes in body
- Pipe connections 1/4 (G*) have standard combination thread according to ISO 228/1 and ISO 7/1. Pipe connections G 1/8 have standard thread according to ISO 228/1
- Installation/maintenance instructions are included with each valve

SPARE PARTS KIT

catalogue number	spare parts kit no.		
	~	=	maintained man. operator
SCE272A001/002/003	C140040	C140040	C140048
SCE272A004/005	C140040	C140040	C140048
SCE272A031/032/033	C140040	C140040	C140072
SCE272A034/035	C140040	C140040	C140072
SCE272A016/017/018	C140040	C140040	C140048
SCE272A019/020	C140040	C140040	C140048
SCE272A046/047/048	C140040	C140040	C140072
SCE272A049/050	C140040	C140040	C140072
SCE272A007	C140038	-	C140048
SCE272A022	C140038	C140038	C140048
SCE272A037	C140038	-	C140072
SCE272A052	C140038	C140038	C140072

ORDERING EXAMPLES:

SC	E	272	A	016	MS	230V / 50 Hz
SC	E	272	A	046	V	115V / 50 Hz
SC	E	272	A	007	MS	24V / DC
SC	E	272	A	052		230V / 50 Hz

prefix — pipe thread — basic number — voltage — suffix

ORDERING EXAMPLES KITS:

C140040 ⁽¹⁾	
C140038	V
C140038	E

basic number — suffix

DIMENSIONS (mm), WEIGHT (kg)



TYPE 01
Prefix "SC" Solenoid
Epoxy moulded
IEC 335 / ISO 4400
IP65

SCE272A001/002/003/004/005

SCE272A007

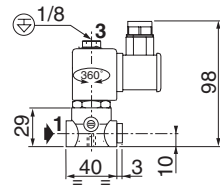
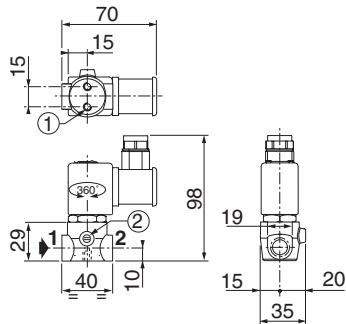

SCE272A031/032/033/034/035

SCE272A037

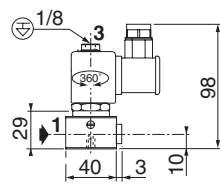
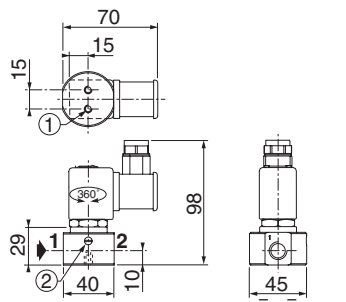

- ① 2 mounting holes Ø M4, depth 6 mm.
- ② Manual operator location.



TYPE 02
Prefix "SC" Solenoid
Epoxy moulded
IEC 335 / ISO 4400
IP65

SCE272A016/017/018/019/020

SCE272A022

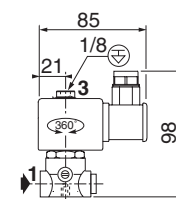
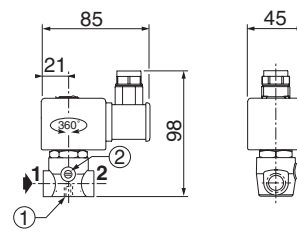

SCE272A046/047/048/049/050

SCE272A052

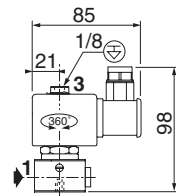
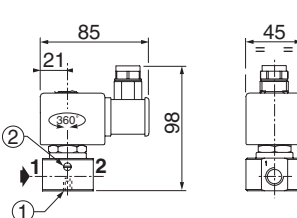

type	prefix option	catalogue number	weight ⁽²⁾
01	SC	SCE272A001/002/003/004/005	0,34
		SCE272A031/032/033/034/035	0,41
		SCE272A007	0,37
		SCE272A037	0,45
02	SC	SCE272A016/017/018/019/020	0,51
		SCE272A046/047/048/049/050	0,56
		SCE272A022	0,54
		SCE272A052	0,60

⁽²⁾ including coil and connector..